

# State Propagation for Business Process Monitoring on Different Levels of Abstraction

19<sup>th</sup> European Conference on Information Systems  
June 9, 2011

**David Schumm**, Gregor Latuske, Frank Leymann,  
Ralph Mietzner, Thorsten Scheibler



*Institute of Architecture  
of Application Systems*

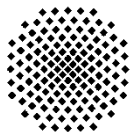

**Universität Stuttgart**  
Germany

**SimTech**  
Cluster of Excellence

<http://www.simtech.uni-stuttgart.de/>

# Overview

- Problem Statement
- The Vision
- How to get there
  - Application Scenarios
  - State Propagation Patterns
  - State Projections
  - Generic Architecture
- Current Limitations and Future Work

# Problem Statement

# Problem Statement

- Current status of a process instance is *undefined* on high-level

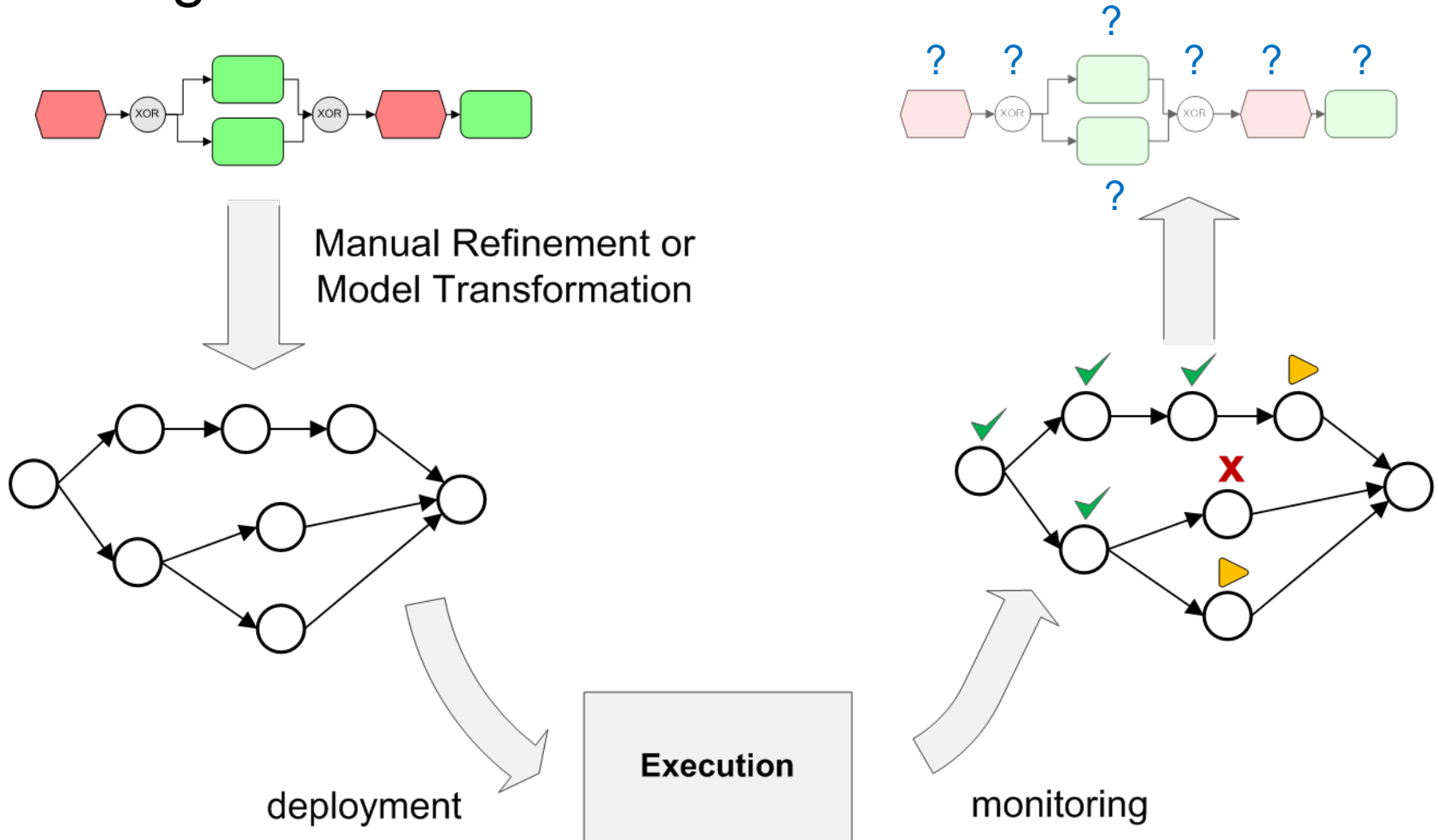

# The Vision

# The Vision

- Propagation of states *across the borders* of process models and process languages

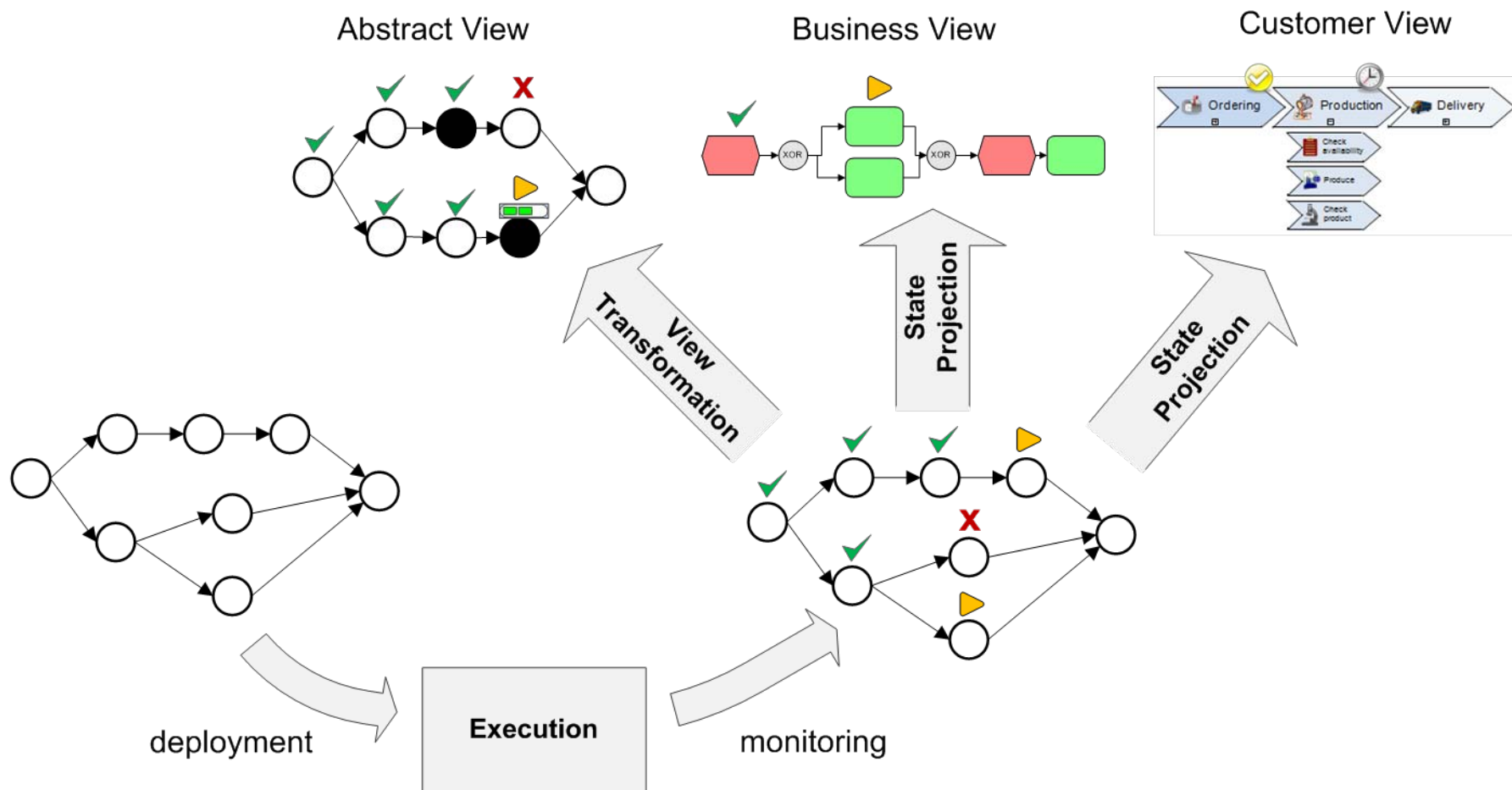

# **How to get There: Application Scenarios**

# Application Scenarios for Pattern Identification

- Abstract process modeling and custom monitoring

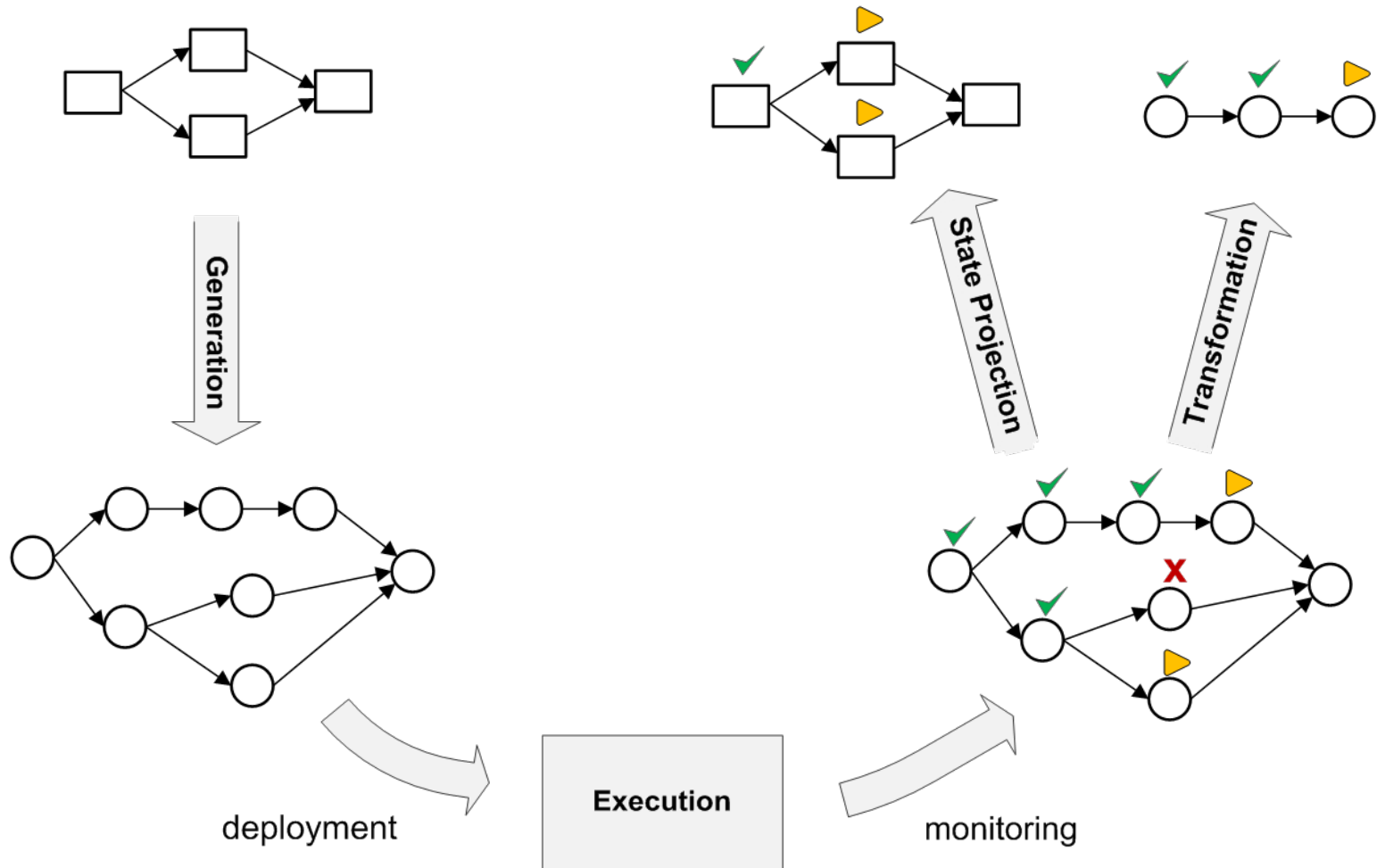

# Application Scenarios for Pattern Identification

- Abstract process modeling and custom monitoring

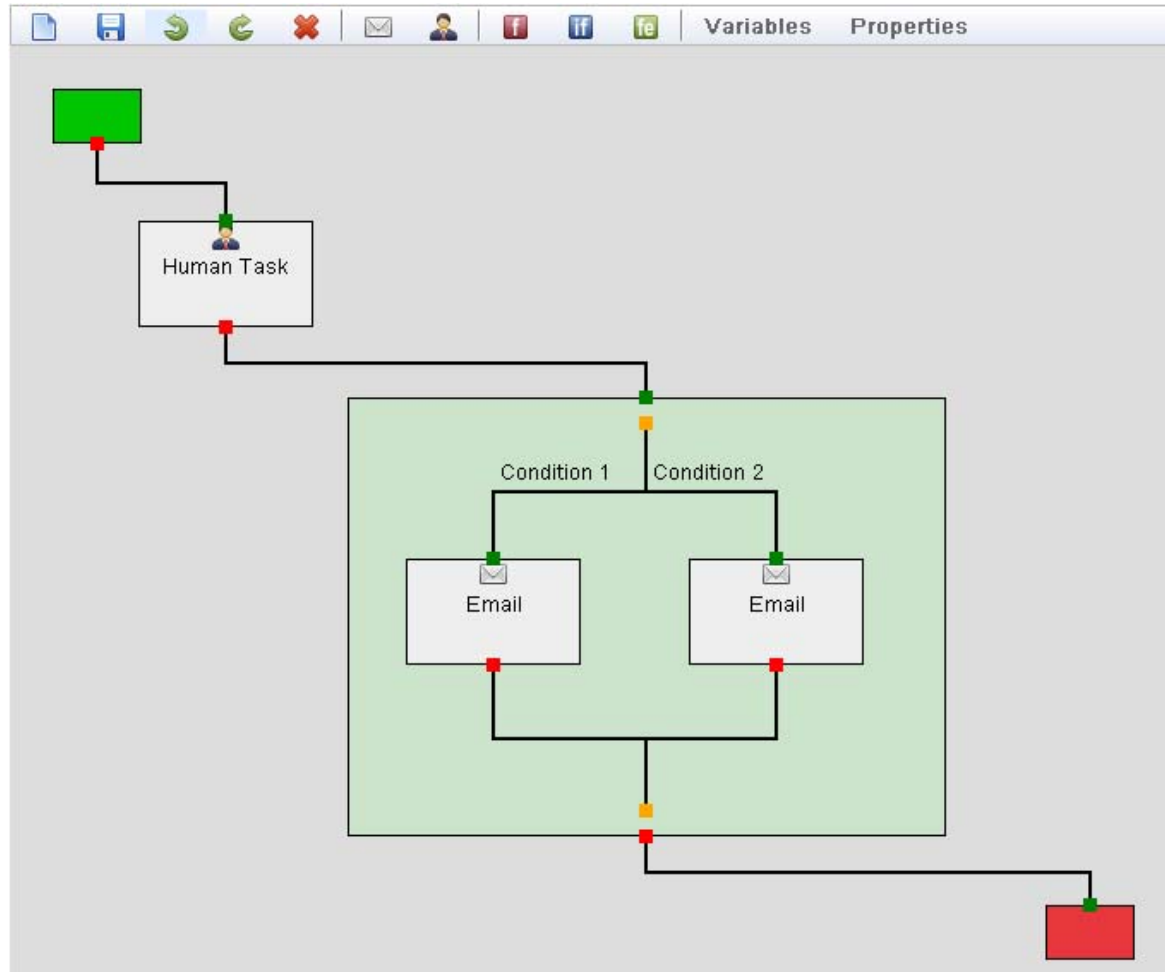

# Application Scenarios for Pattern Identification

- Modeling and monitoring in integration scenarios

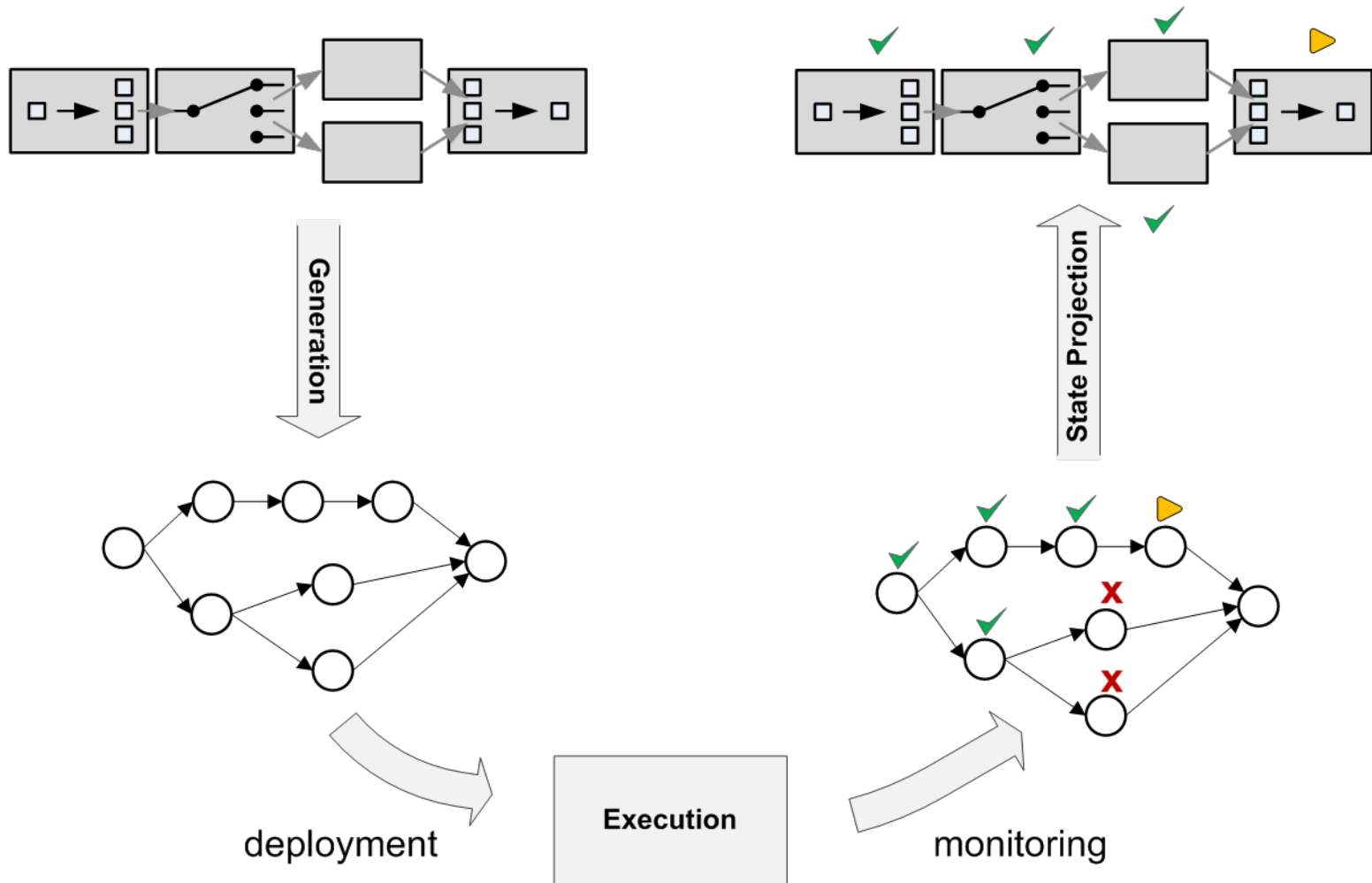

# Application Scenarios for Pattern Identification

## ■ Modeling and monitoring in integration scenarios

The screenshot displays an ESB modeling tool interface. The main workspace shows a complex integration scenario diagram with various components like queues, routers, and external services. The Project Explorer on the left shows the project structure. The Console at the bottom displays two errors related to an aggregator configuration.

**Project Explorer:**

- Integrationsolution
  - loanbroker.eai
  - loanbroker2.eai
  - LoanBroker

**Diagram Components:**

- Start Queue
- Router
- Queue
- Aggregator
- Three External Services
- Queue
- Router
- End Queue

**Console Errors:**

2 errors, 0 warnings, 0 others

Description
✖ Errors (2 items)
✖ An Aggregator must have one of the following completeness conditions: 'wait for all', 'timeout', 'first best', 'external event'.
✖ An Aggregator with no access to an external web service must have a best element.

# **How to get There: State Propagation Patterns**

# State Propagation Patterns

- Direct state propagation

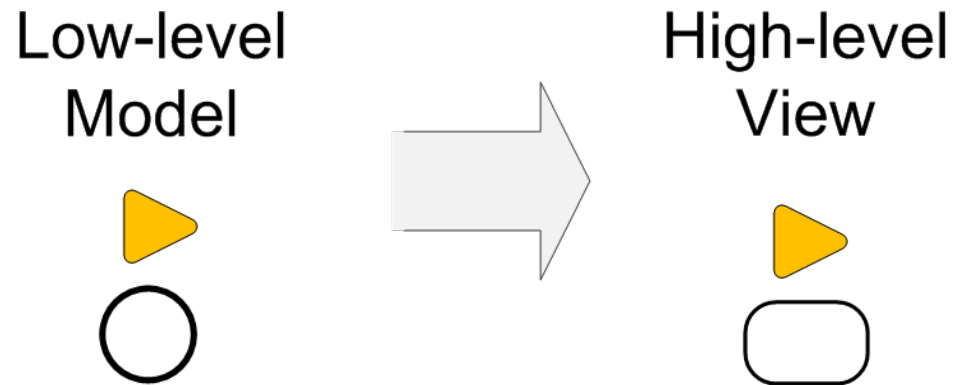

# State Propagation Patterns

- State alteration

Low-level  
Model

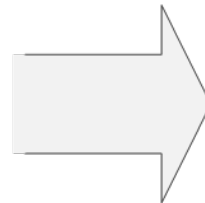

High-level  
View



# State Propagation Patterns

- State combination

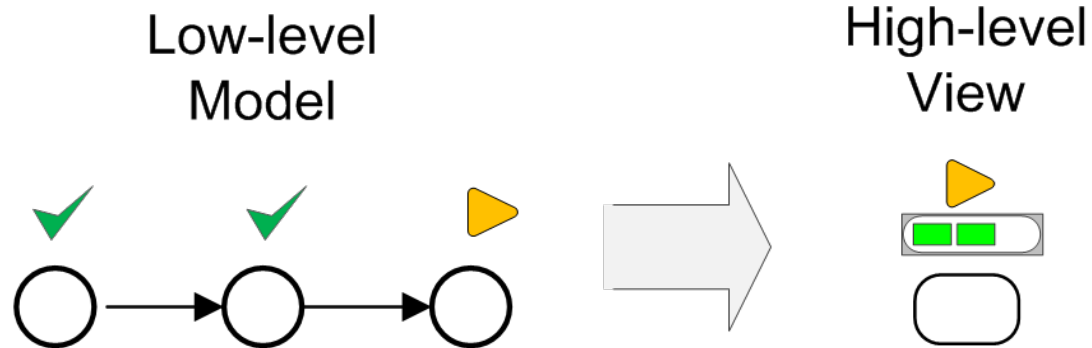

# State Propagation Patterns

- State deduction

Low-level  
Model

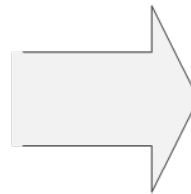

High-level  
View



# State Propagation Patterns

- Transition state

Low-level  
Model

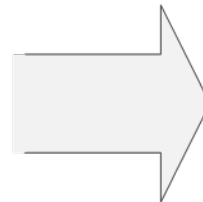

High-level  
View



# State Propagation Patterns

- Instance state aggregation

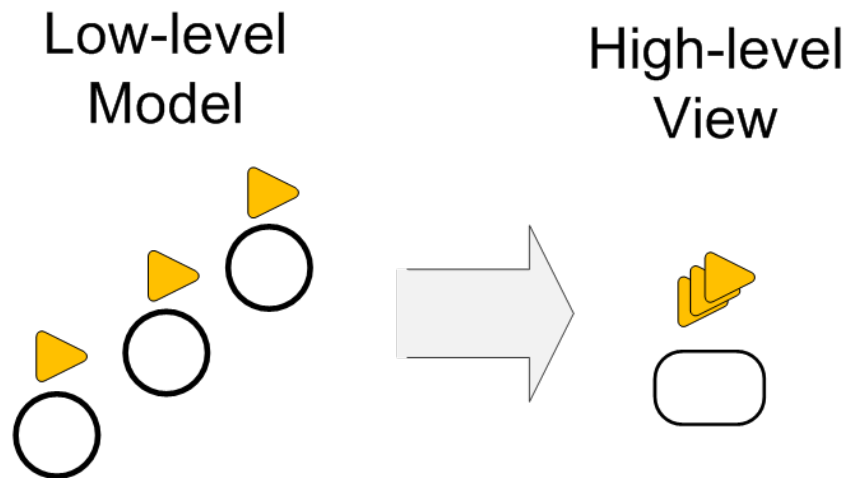

# How to get There: State Projections

# State Projections

## ■ Abstract Process Modeling and Custom Monitoring

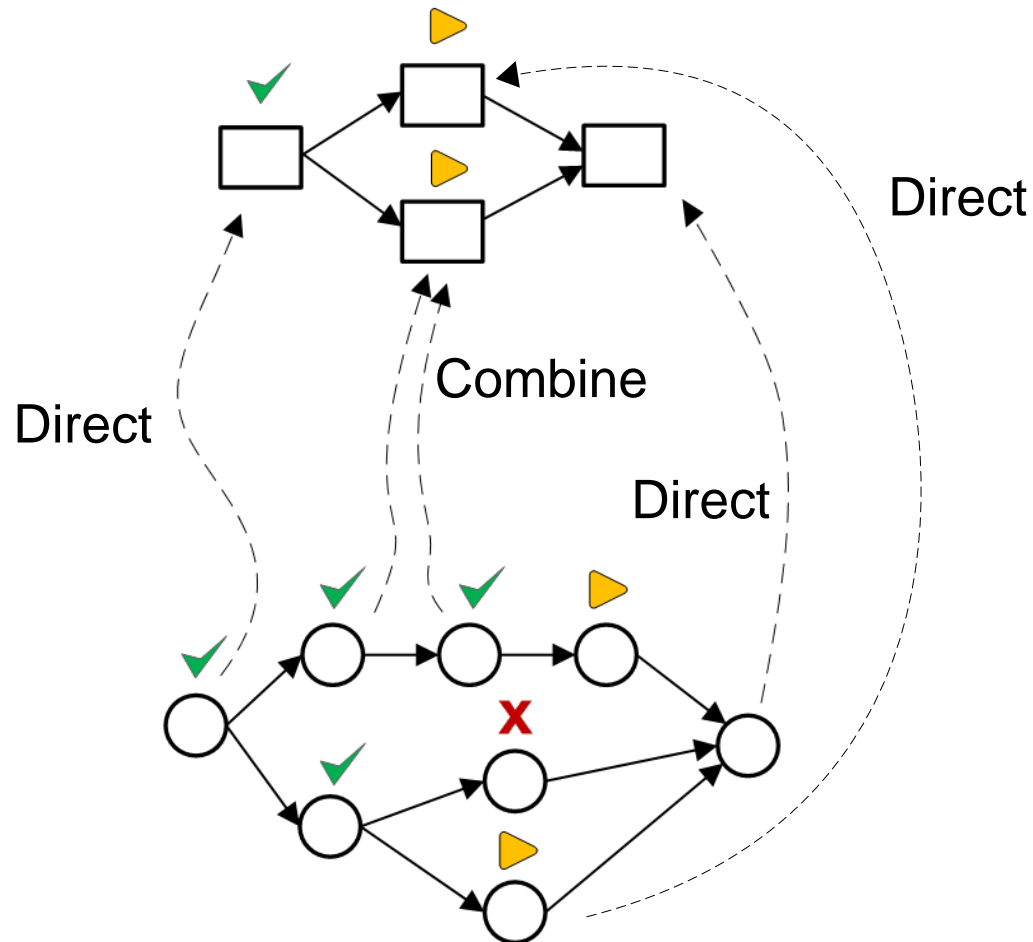

# State Projections

## ■ Modeling and Monitoring in Integration Scenarios

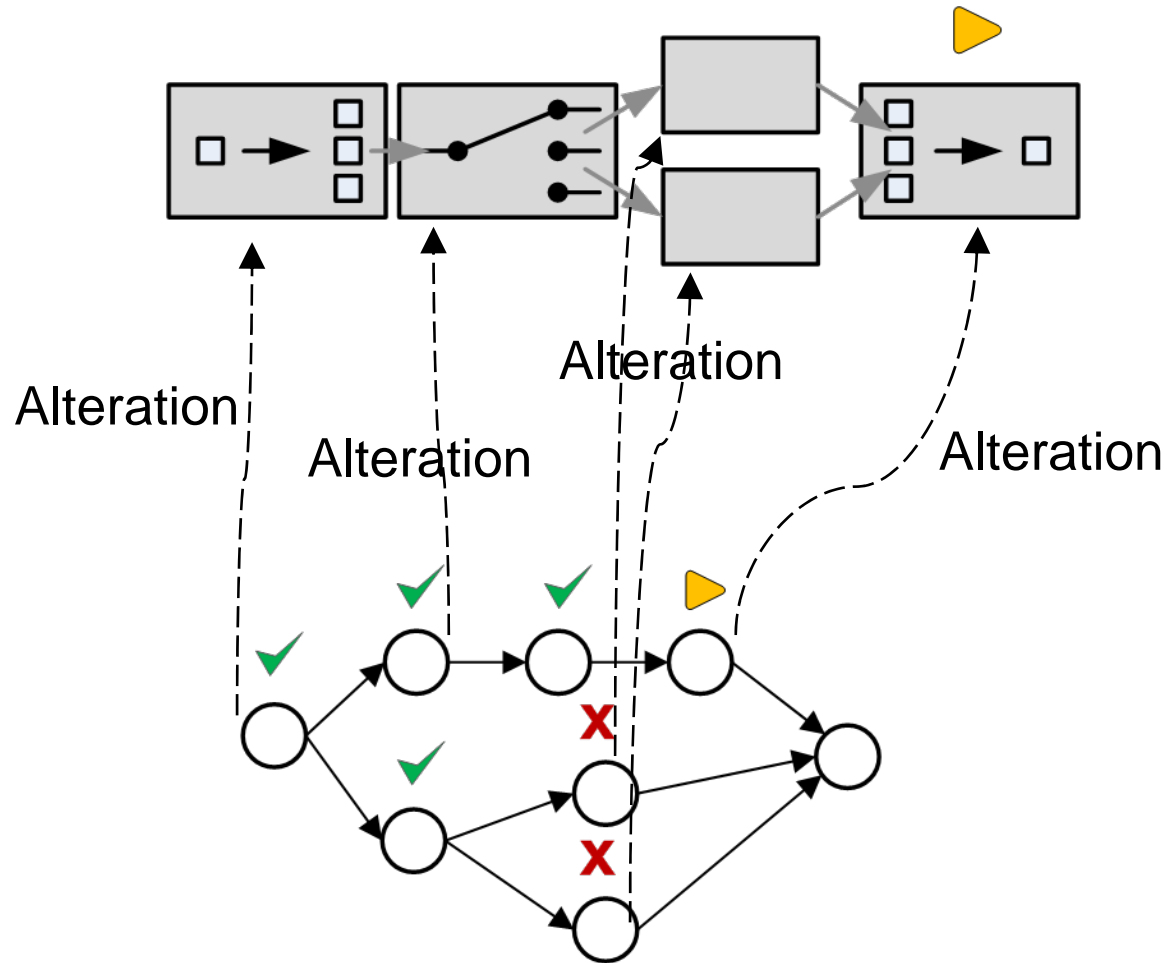

# State Projections: Instance State Aggregation

- Modeling and Monitoring in Integration Scenarios

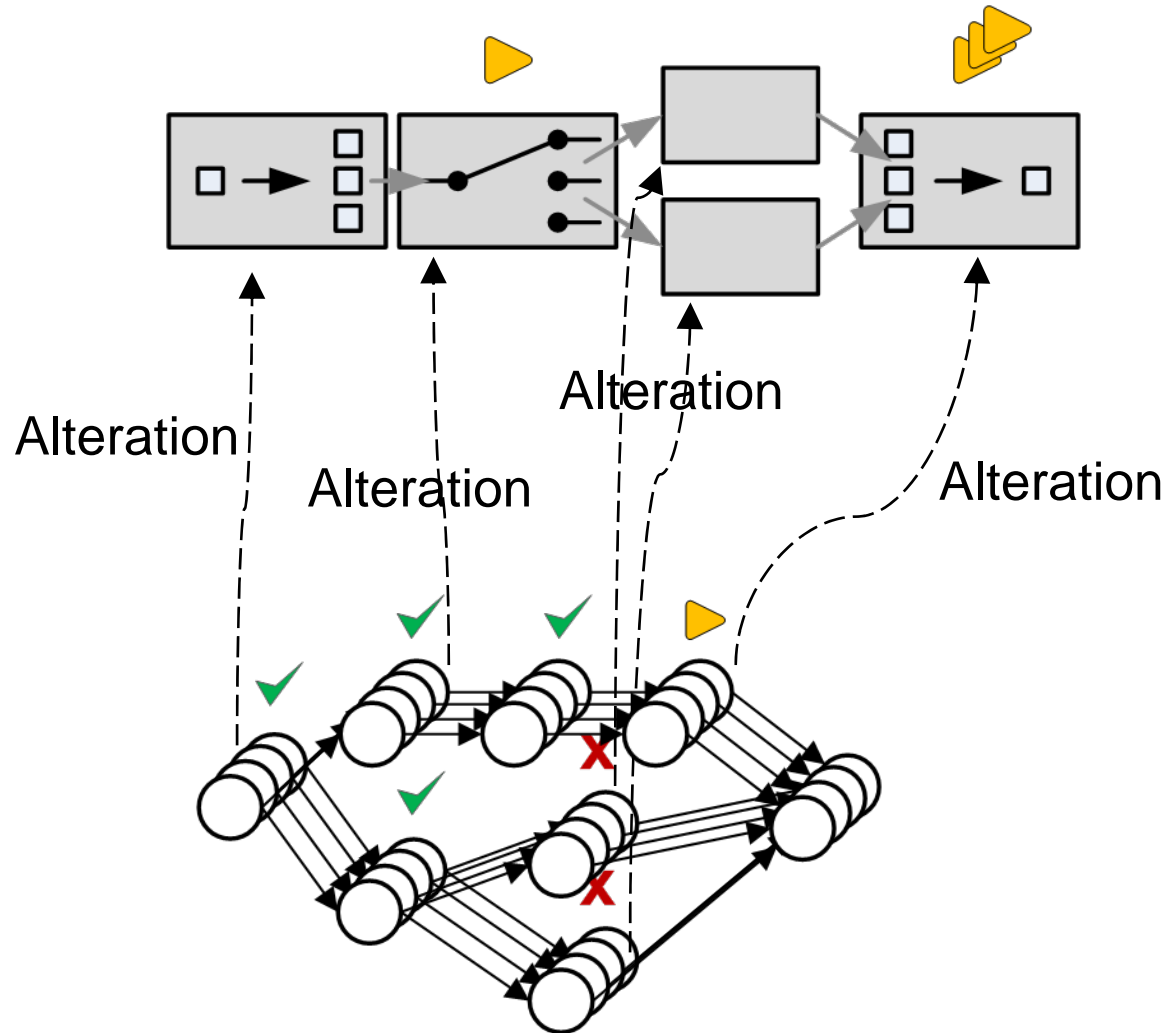

# **How to get There: A Generic Architecture**

# How to get There: A Generic Architecture

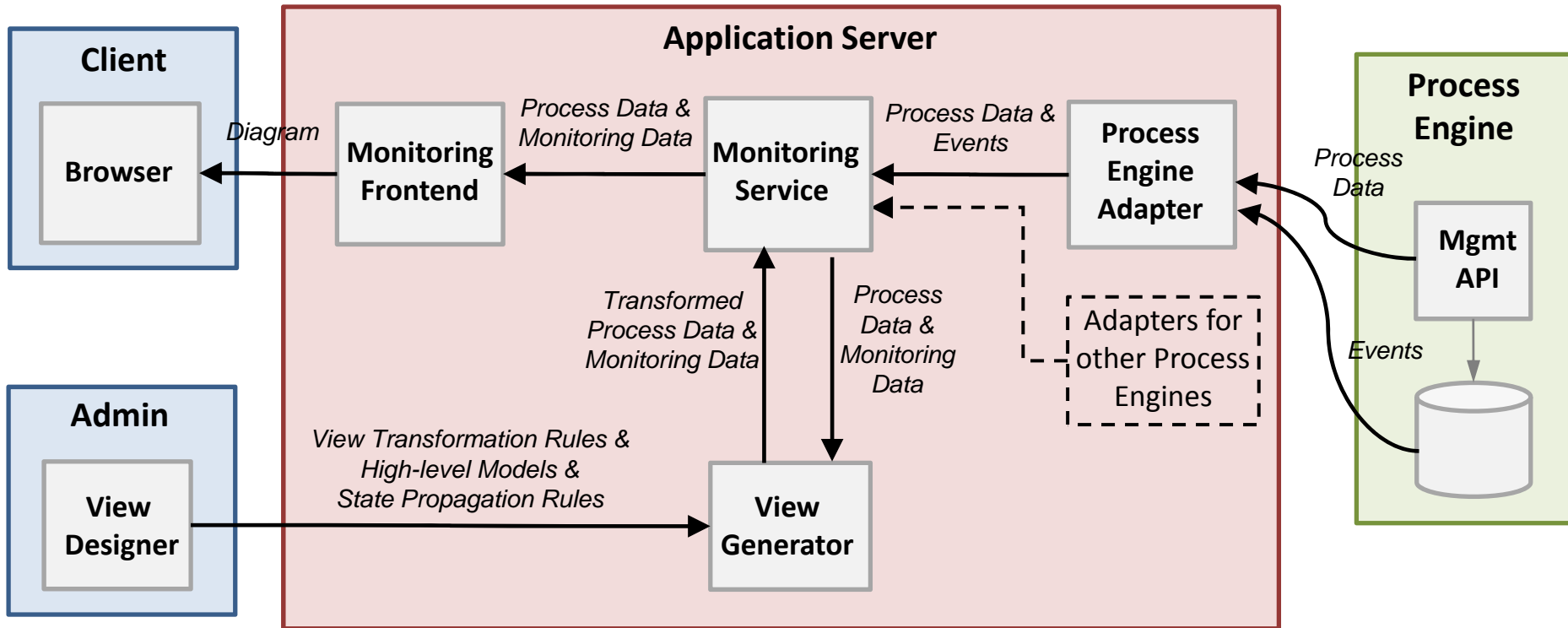

# **Current Limitations and Future Work**

# Current Limitations and Future Work

- Undesirable projection phenomena
  - Token jumps in dead paths
  - Tokens appearing twice in block structures
- Projection soundness
  - Across process models
  - Across process languages
  - In multi-level projections
- State propagation patterns
  - Pattern composition
  - Algebra for state propagation