



Institute of Architecture of Application Systems

---

## A Proposal of BPMN Extensions for the Manufacturing Domain

Sema Zor, David Schumm, Frank Leymann

Institute of Architecture of Application Systems,  
University of Stuttgart, Germany  
sema.zor@iaas.uni-stuttgart.de

---

**BIB<sub>T</sub>E<sub>X</sub>:**

```
@inproceedings{Zor2011,  
  author    = {Sema Zor and David Schumm and Frank Leymann},  
  title     = {A Proposal of BPMN Extensions for the Manufacturing Domain},  
  booktitle = {Proceedings of the 44th CIRP International Conference on  
              Manufacturing Systems},  
  year      = {2011},  
}
```

© 2011 Sema Zor, David Schumm, Frank Leymann

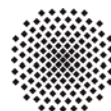

**Universität Stuttgart**  
Germany

# A Proposal of BPMN Extensions for the Manufacturing Domain

S. Zor<sup>1,2</sup>, F. Leymann<sup>2</sup>, D. Schumm<sup>2</sup>

<sup>1</sup> Graduate School for Advanced Manufacturing Engineering, University of Stuttgart, Germany

<sup>2</sup> Institute of Architecture of Application Systems, University of Stuttgart, Germany

## Abstract

The manufacturing domain can be characterized by the concepts of product, process and resource. The coordination of humans, machines and materials is needed to attain a desired product by using knowledge, time, money and energy optimally. Business processes define such coordination. Business Process Model and Notation (BPMN) is an industry standard for modeling business processes. This standard is not being applied to the manufacturing domain so far. In this paper, we propose BPMN extensions to support process modeling in the manufacturing domain, especially the modeling of production processes. We motivate and justify our proposed extensions by an exemplary assembly process.

## Keywords:

Manufacturing Process Modeling, Production Process Modeling, BPMN

## 1 INTRODUCTION AND MOTIVATION

A business process consists of a set of activities to produce a product or provide a service. A process model describes the structure of a business process in the real world. It defines all possible paths through the business process, including the rules that define which paths should be taken and all actions that need to be performed. A process model is a template from which process instances are created [1]. Several standards to model business processes exist. One is the Business Process Model and Notation (BPMN) [2] which is recently gaining momentum in the business domain. It has been developed to enable business users to design readily understandable graphical representations of business processes. In addition, BPMN is supplemented by appropriate object properties that enable the generation of executable processes in the Business Process Execution Language (BPEL) [3]. In general, BPMN is used to model *paper processes* such as approving a loan in a bank. BPMN offers clear semantics to describe the business processes of a company. From the business side, BPMN is already used as a standard modeling language and can possibly make the different modeling languages used in that field obsolete. We envision that BPMN, when used both at shop floor level and at business level, closes the gap between enterprise management level and manufacturing operations level. We see the main reason for this gap in the different communication methods and modeling languages used at the different levels. By using one *common* language, business analysts will be enabled to work with manufacturing processes, as well. Using one common language, the analysts can easily understand, model and optimize the manufacturing processes, and communicate with engineers about their core competencies. Due to using a standardized language, processes can be understood and adopted faster, and be communicated more precisely.

In the manufacturing domain we find paper processes as well. For instance, these are processes for production planning, order management, purchasing, logistics, or change requests on products. In order to model such processes we need to express the flow of control and information (data) through the process steps. BPMN

provides such language constructs. Thus, these processes can already be modeled using BPMN.

However, the paper processes in the manufacturing domain which consist of control and information flows can be characterized as “auxiliary flows”. They basically support and manage the actual manufacturing processes. The manufacturing processes are the core processes and the main objective of any manufacturing company. Here, we propose a distinction between the terms manufacturing processes and production processes. A *manufacturing process* is a transformation activity in which employees use machines, energy and information to transform material into products [4]. Within the production flow, the movement of material through the factory is the most prominent type of flow that usually comes to mind. Additionally, the information flow that tells each manufacturing process what to do next has to be considered, too [5]. A *production process* is a superset of all kinds of processes in a manufacturing company. Production processes include all business processes which are performed in a manufacturing company, plus the manufacturing processes.

Elements	Business Domain	Manufacturing Domain
Activity	Task	Task, manufacturing task
Human activity	Human task	Manual task
Information	Business object	Business object, operating data, machine data
Material	Documents	Documents, goods (raw material, parts and finished goods), auxiliary material
Resource	Humans, computing resource	Humans, machines, tools

Table 1: Clarification of terminology.

In this paper we focus on modeling of manufacturing processes with BPMN. We investigate which extensions are required to model these processes, e.g., to model the movement of material.

Table 1 compares the terminology of typical business processes, such as a loan approval in a bank, to production processes in a manufacturing company. The differences in the terminology already point to a need for extensions in order to express the different concepts.

The paper's further structure is the following: Section 2 describes work related to our approach. In Section 3, we present an exemplary scenario which motivates and justifies the proposed extensions. Our main contributions, the BPMN extensions we propose, are elaborated in Section 4. In Section 5, we apply the extensions to the exemplary scenario. Section 6 summarizes the paper and characterizes future work.

## 2 RELATED WORK

Business process management in a service industry basically encompasses process modeling (on which we focus in this paper), process execution, process monitoring, and process analysis. Nowadays, various different languages are used in process modeling. For instance, the language Event-driven Process Chains (EPC) [6] is widely used for the design of processes related to SAP systems. UML Activity Diagrams [7] is a language that is more common in technical applications, like in the description of software processes. Although Microsoft PowerPoint as well as Microsoft Word are tools which do not specify a language for business process design, they are widely used for this purpose as well. As already mentioned in the introduction, a language for business process design that is recently gaining momentum is the Business Process Model and Notation (BPMN) [2]. BPMN is an industry standard developed by the Object Management Group (OMG). It defines a graphical notation and according semantics for business processes. The authors of this language intended to design a language that can be used by both, management and technical staff.

Due to the increasing usage and acceptance of BPMN for business process design, more and more extensions to BPMN are proposed. For example, in [8] extensions to capture the interaction behavior between multiple process partners have been proposed. These extensions allow the representation of multiple participants in different sets, correlations, and reference passing. Another extension to BPMN is discussed in [9]. In this work new language elements are proposed that allow the integration of security aspects in a business process. For instance, a task can be annotated to comply with particular access control requirements. However, to the best of our knowledge, there exist no extensions to BPMN that allow modeling a process model with the requirements given in the manufacturing domain, in other words, for modeling a production process.

## 3 EXAMPLE SCENARIO

According to [10], processes at shop floor include the manufacturing of components, the assembly and the testing of parts. In this section, we describe an assembly process which we use in Section 4 to motivate and exemplify our extensions. We also investigated the requirements of a manufacturing process, but due to space limitations we can only place the assembly process in detail. The representation of this process using the BPMN extensions is given in Section 5.

The scenario describes the checking an ignition plug, see the BPMN diagram in Figure 1. The process consists of human tasks, i.e., tasks that are expected to be

performed without the aid of automation. In this example, the worker has to perform the following three major steps:

- Disassembly
- Checking the ignition plug
- (Re-)assembly

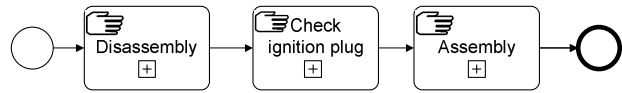

Figure 1: Example scenario on abstract level.

In detail, we can break down these high-level steps (so-called sub-processes in BPMN) into 16 manual tasks in total. We can also use standard BPMN for modeling the detailed version of the process, see Figure 2.

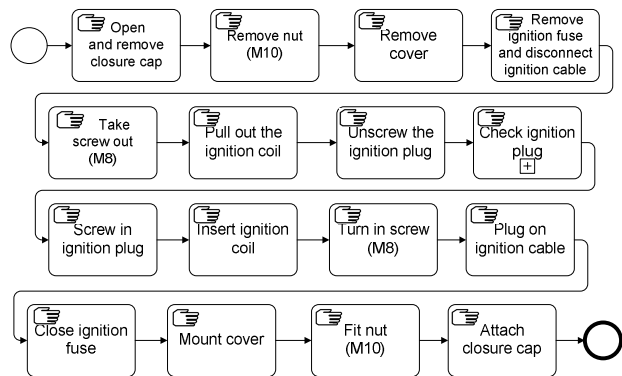

Figure 2: Example scenario on concrete level.

The labels of the activities in the Figure 2 correspond to the enumeration of the steps 1-16 below.

However, as mentioned in the introduction, not all details of the assembly process can be modeled with standard BPMN. In the detailed description of the process below we highlight in bold the aspects of the process which could **not** be modeled with standard BPMN. For modeling these aspects language extensions are necessary.

1. Open and remove the **closure cap**.
2. Remove **nuts** with a **wrench**.
3. Remove **cover**.
4. Remove **ignition fuse** and disconnect **ignition cable**.
5. Take **screw** out, use **screwdriver**.
6. Pull out **ignition coil**.
7. Unscrew the **ignition plug**, use **wrench**.
8. Check **ignition plug**.
9. Screw in checked **ignition plug**.
10. Insert **ignition coil**.
11. Turn in **screw**, use **screwdriver**.
12. Plug on **ignition cable**.
13. Close **ignition fuse**.
14. Mount the **cover**.
15. Fit **nuts**.
16. Attach the **closure cap**.

## 4 EXTENDING BPMN

The BPMN specification [2] defines an extensibility mechanism that allows adding graphical elements and new features like attributes or markers to the modeling notation. We use this mechanism to provide support for the additional elements which are needed to model processes from the manufacturing domain. However, in order to create a BPMN-compliant extension, there are some rules which have to be followed. First of all, the extensions must not contradict the semantics of any element that is defined in the specification. This includes that the shapes defined in the specification must not be changed, and the shapes of extension elements must not conflict with the shapes defined in the specification. Furthermore, the graphical elements should be easy to understand by any viewer of the process diagram. In addition, the extension elements should have the "look-and-feel" of BPMN. The main purpose of these rules is that the particular requirements of different domains can be satisfied, while maintaining a "valid BPMN core", that can be easily understood by business experts.

In particular, BPMN permits the following extensions:

- Additional attributes may be added to the elements defined in the specification.
- Additional markers and indicators may be added to graphical elements which are already defined in the specification; these markers can be bound to extended attributes.
- Additional graphical elements representing any kind of artifact may be added.
- Usage of colors for defining semantics is permitted.

The extensions we propose are motivated by several considerations. Firstly, we tried to model exemplary scenarios, such as the one introduced in Section 3, using existing BPMN constructs. We derived extensions from the aspects which could not be modeled. Secondly, by comparing manufacturing processes and business processes based on literature study [1, 2, 10, 11, 12, 13, 14, 15, 16, 17], we derived further extensions. We do not claim to provide a complete list of extensions which are required for the modeling of any manufacturing process.

The BPMN extensions we introduce represent some crucial concepts of the manufacturing domain. These concepts are, for instance, manufacturing processes or material objects (i.e., resources). Furthermore, we consider the movement of material and how it can be converged or diverged. In order to be BPMN-compliant, our BPMN extensions are extensible, as well. Thus, new properties can be defined for the extensions, if required for a particular scenario.

In this Section we adopt the following structure to explain an extension:

### ExtensionName

- **Meaning:** Here, we explain the construct of the manufacturing domain which has to be introduced in BPMN.
- **Description:** We describe how this construct can be translated to BPMN.
- **Properties:** Properties – if there are any – which are relevant and applicable in BPMN.
- **Icon:** At the end of each section a symbol is shown which represents the new extension element.

### 4.1 Activity Type for Manufacturing Processes

#### Manufacturing Task

**Meaning:** Manufacturing processes use machines, tools and labor to produce goods by transforming raw

materials into finished goods, e.g., marking out a pattern to a work piece.

**Description:** To represent manufacturing processes we introduce a new activity type *Manufacturing Task*. A *Manufacturing Task* is an atomic activity within a production process flow. This task is used when the work in the production process cannot be broken down to a finer level of detail. A *Manufacturing Task* object is a rectangle that has rounded corners. The marker for the *Manufacturing Task* is a little factory shape located within the rectangle (upper left), see Figure 3.

**Properties:** Depending on the concrete manufacturing process we can specify for each process cycle time, set-up time, fit tolerance, number of involved persons, or machine reliability, etc.

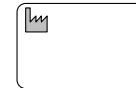

Figure 3: Manufacturing Task.

### 4.2 Resource Containers

Usually resources in manufacturing domain capture humans, machines and tools. In this paper, we divide resources in *Machines and Tools*, *Parts*, and *Auxiliary Material* as shown in Figure 4. We extend BPMN considering machines and tools, and parts. For the modeling of human staff we do not need extensions because BPMN already provides constructs for this (swim lanes, pools) [18].

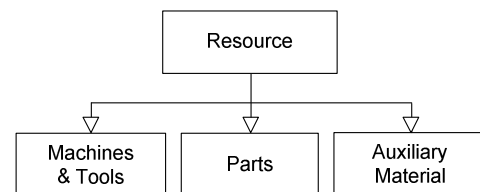

Figure 4: Conceptual Model of the Resources.

In order to make our approach applicable in industrial practice, we envision libraries of machines and tools, parts and auxiliary material. These libraries may contain graphical shapes of these artifacts, detailed specifications, and properties. Such libraries are likely to be provided by material suppliers, tools and machinery suppliers, or standardization organizations such as DIN or ISO. Kosanke [19] already presents some considerations about business process modeling and standardization. The modeling environment needs to integrate these libraries to make the shapes and related information available for process modeling.

#### Machines & Tools Container

**Meaning:** Machines and tools are fixed components of each production facility. These devices are used within manufacturing processes, like a wrench or a milling machine.

**Description:** For this, we introduce a new element *Machines & Tools Container*. This construct groups all material objects flowing from or to the related *Manufacturing Task*. It is represented by a rectangle which can be collapsed to see the involved machines and tools. The container must be connected to a *Manufacturing Task* by a *Machines & Tools Flow Connector* (Section 4.3). See Figure 5 a).

**Properties:** Within this construct we can specify the properties identifier, quantity, moveable, non-moveable, safety information, and authorized persons (roles or qualification level).

### Parts Container

Meaning: The most important material that flows in a production is the product (or its parts) itself. Depending on the developmental stage of the product, it can be raw material, unfinished parts or goods such as crude oils or ignition plugs.

Description: The *Parts Container* is designed as elliptical shape to represent the part. It can be collapsed to see its concrete and process-specific elements. The *Parts Container* can either be connected to a *Manufacturing Task* or a *Material Gateway* (Section 4.4) by using *Parts Flow Connectors* (Section 4.3). See Figure 5 b).

Properties: Possible properties for elements in the *Parts Container* could be product shape information, quantity, identifiers, processing status, and so on.

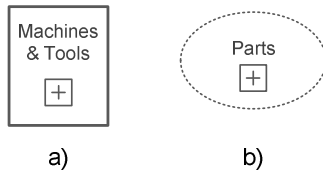

Figure 5: Machines & Tools Container (a) and Parts Container (b).

### 4.3 Connector Types for the Movement of Material

Different resource types are supposed to be represented by different connectors in order to clearly distinguish if the flowing material is a (product-) part or a tool. Thus, we made a distinction between “parts flow” and the “tools flow”.

#### *Machines & Tools Flow Connector*

Meaning: As already mentioned, in each production facility we have fixed and moveable machines and tools.

Description: In order to model the movement of these machines and tools, we introduce a *Machines & Tools Flow Connector*. Each *Machines & Tools Flow Connector* has exactly one source and exactly one target. The source and target must be of the type activity (task or sub-process) or gateway. A *Machines & Tools Flow Connector* is a broken line with a solid arrowhead. See Figure 6 a).

Properties: We can indicate involved persons and/or the type of transportation.

#### *Parts Flow Connector*

Meaning: We need a construct which indicates a transfer of a product material from one source to one target. It represents raw material, parts or finished goods. The material can be transferred by human, via machine, or via using an assembly line. For example taking out an ignition coil from the *Parts Container* and transferring it to the task “Insert the ignition coil”, see Figure 9.

Description: In order to indicate the “parts flow”, we propose a *Parts Flow Connector* which connects *Manufacturing Tasks*, *Parts* or *Material Gateways* with each other, also across sub-process borders. The *Parts Flow Connector* is a broken line with an unfilled arrowhead. See Figure 6 b).



Figure 6: Machines & Tools Flow Connector (a) and Parts Flow Connector (b)

Properties: The most important property is the material access mechanism which should be used. Here, the access mechanisms to the material can be “push”, “pull (kanban)”, first-in-first-out or last-in-first-out order.

### 4.4 Material Gateways

In BPMN, gateways are used to control how sequence flows interact as they converge and diverge within a process [2]. For the new connector types introduced in Section 4.3 which show how material flows, we need gateways in order to control the interaction of converging and diverging material flows as well. A gateway is only needed if the flow needs to be controlled. We name these gateways *Material Gateways* which are necessary to represent different routing, joining and splitting scenarios of material. The particular properties of production line specifications are not considered yet. For this purpose, the *Material Gateways* can be extended. For instance, we could indicate time specifications for the activation of a gateway. Each type of *Material Gateway* has a marker to show the type of gateway that is being used. The *Material Gateway* icons presented in Figure 7 are based on the “Enterprise Integration Patterns” by Hohpe et al. [20]. The following *Material Gateways* have common properties: all of them decide whether they route, select, split, or join depending on the condition to be checked.

#### *Material Route Gateway*

Meaning: Basically, this construct is a diversion point in the material flow. For instance, we use this gateway in Figure 8 to decide if a defective ignition plug could be repaired or is waste.

Description: A diverging *Material Route Gateway* is used when alternative paths within a process could be taken. With this gateway we can model a decision which can be thought of as a question that is asked at a particular point in the production process. A set of answers has to be defined for this question. See Figure 7 a).

Properties: The mechanism (human or a particular machine) that is used to evaluate the routing condition.

#### *Material Select Gateway*

Meaning: In shop floor environments we have the scenario to select one out of multiple materials which has to be routed through the production process. For example, after checking the ignition plug we decide if we need a new one or screw in the existing ignition plug.

Description: The *Material Select Gateway* has multiple incoming flows and one outgoing flow. If there is at least one incoming flow the gateway reacts by giving through this flow. See Figure 7 b).

#### *Material Split Gateway*

Meaning: We need a construct, which indicates the splitting of material.

Description: The *Material Split Gateway* creates parallel flows by dividing material into multiple constituent parts. The condition specifies how the material has to be split up. See Figure 7 c).

#### *Material Join Gateway*

Meaning: Joining resources is an indispensable scenario in production environments such as screwing in an ignition plug in a motor.

Description: The *Material Join Gateway* controls incoming resources. It waits for the completion of all incoming flows before triggering the flow through its outgoing flow. See Figure 7 d).

Properties: Joining resources needs the specifications like the roles of persons, the number of involved persons and/or the types and numbers of machines and tools.

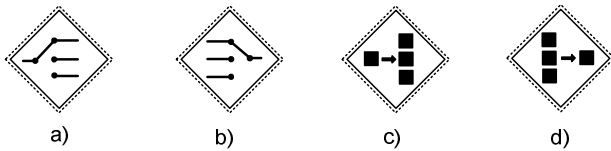

Figure 7: Material Route Gateway (a), Material Select Gateway (b), Material Split Gateway (c), Material Join Gateway (d)

## 5 MODELING WITH EXTENDED BPMN

In Figure 9 the example scenario which we introduced in Section 3 is shown. In the business process diagram shown in Figure 9 we made use of the BPMN extensions proposed in Section 4. The most significant differences compared to the version without extensions (shown in Figure 2) are the additional connectors for flow of parts and tools. Furthermore, the respective tools like a wrench and parts like an ignition coil are contained in the process. The BPMN extensions allow putting much more information into the process model which makes the process more complete from a manufacturing point of view. However, compared to the version without extensions shown in Figure 2, the process model also experiences a significant increase of complexity when making use of the extensions. The more details are modeled in the process, the harder it becomes to read and to understand it.

Therefore, we also need techniques to cope with this increasing complexity. The BPMN specification defines the notion of sub-processes which can be used as a technique for abstraction and for modularization. One abstraction mechanism we propose is the collapse/expand feature that the containers for machines

and tools and parts provide. As illustrated in Figure 9, this allows drilling down into details when required (wrench, ignition coil). For instance, this feature is especially useful, when several tools are used in the tasks. In Figure 8 we show another possibility to represent the parts that flow. In this figure the connectors are labeled with the flowing parts.

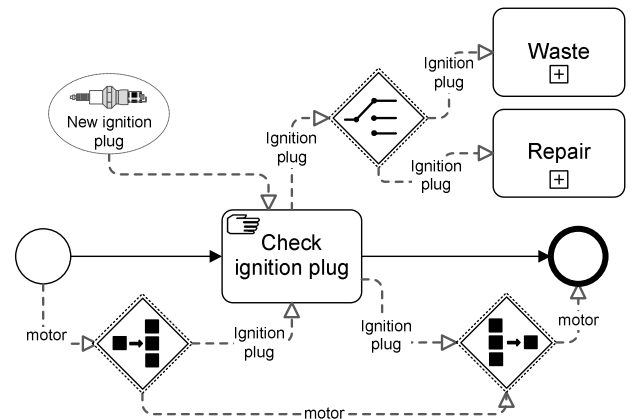

Figure 8: Collapsed sub-process "Check ignition plug"

Although the collapse/expand feature provides for different levels of details, it only tackles a part of the overall complexity. For that reasons, we propose to apply process viewing techniques [21] to process modeling in the manufacturing domain. A process view can be seen as the result of different transformations which are applied to a process model. For instance, particular parts of a process can be hidden or summarized. In fact, we already applied viewing techniques to the example process shown in Figure 9.

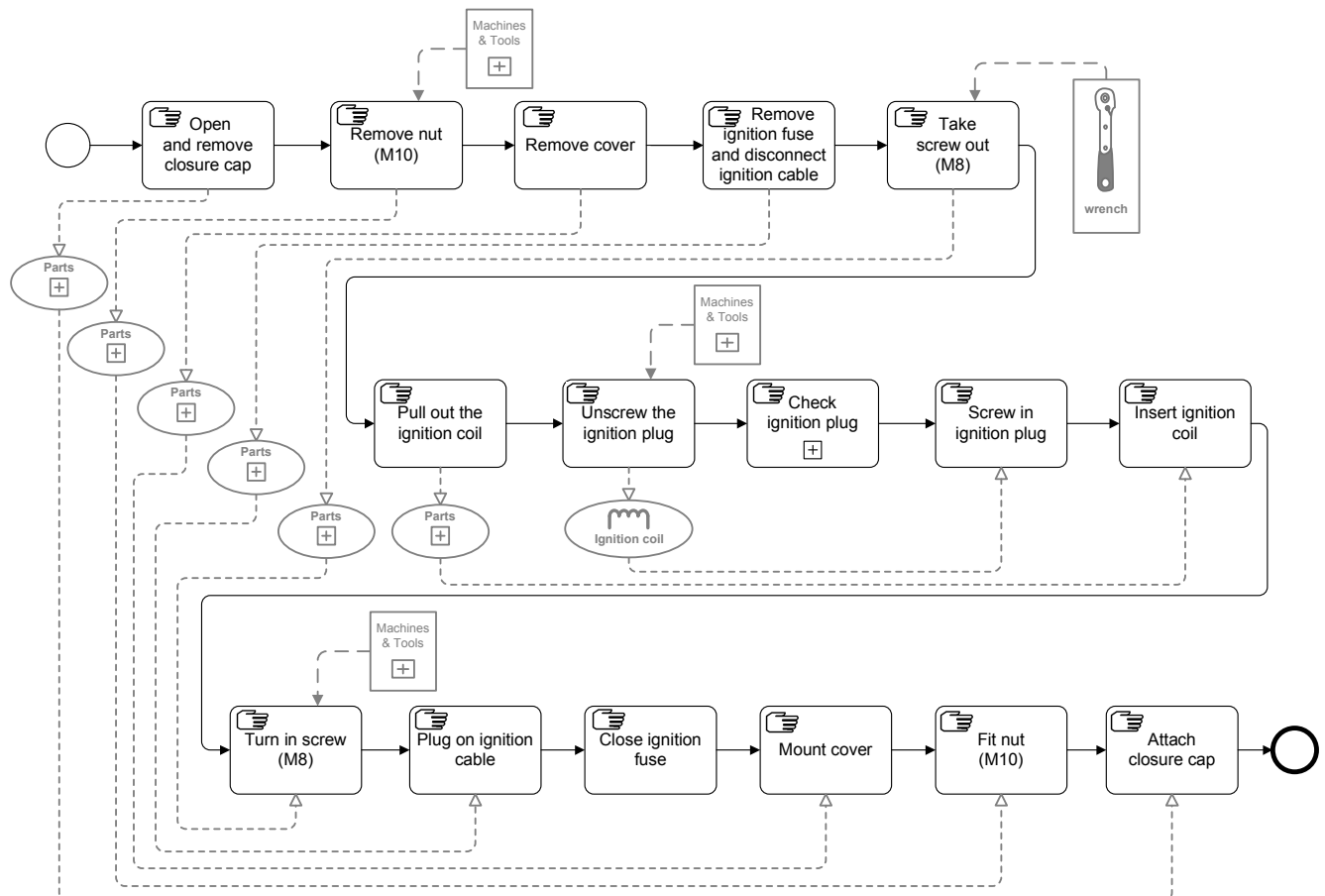

Figure 9: Example Scenario with some BPMN extensions.

We applied the viewing pattern “omission” to the process in order to hide the flow of the motor through the process. In the complete view of process, the motor would be input and output of each task. Process viewing techniques could for instance also be used to completely hide particular aspects of the process like the flow of material, or to highlight special parts. Common usage scenarios for applying such techniques in business process management are discussed in [22]. However, these scenarios do not consider the requirements of the manufacturing domain. More research is necessary for design of process views which are tailored to the information needs of process designers and analysts in this domain. In Figure 8 the “Check ignition plug” sub-process is shown in expanded mode. In this figure we also included the flow of the motor through the tasks. This level of detail also exemplifies the usage of the *Material Gateways*.

## 6 CONCLUSION AND OUTLOOK

This paper has discussed how BPM technologies such as business process modeling with BPMN can be applied in the manufacturing domain. Today's manufacturing companies need to become more flexible to adapt more quickly to fast changing business demands and markets. The presented idea claims that the proper modeling of business processes in the manufacturing domain is a major issue. Modeling processes in BPMN notation means to document processes with well-defined syntax and semantics.

We are currently working on tool support for the presented BPMN extensions. Therefore, we created a Microsoft Visio stencil set that provides the shapes for our extensions. Supporting the modeling of manufacturing flows in extended BPMN based on the web-based modeling tool ORYX [23] is ongoing work. The extension of the BPMN metamodel has to be done following the instructions of the BPMN specification [2, pp. 57].

Furthermore, we are currently investigating the relation of bill of materials and routing plans which define how to produce parts. Our goal is the generation of BPMN diagrams from bill of materials and routing plans (and vice versa) by applying model transformation.

## 7 REFERENCES

- [1] Leymann, F., Roller, D., 2000, Production Workflow: Concepts and Techniques, Prentice Hall PTR.
- [2] Object Management Group: Business Process Model and Notation (BPMN): OMG Available Specification, Version 2.0, January 2011.
- [3] Organization for the Advancement of Structured Information Standards (OASIS), 2007, Business Process Execution Language 2.0 (BPEL), OASIS Standard.
- [4] Jovane, F., Westkämper, E., Williams, D., 2009, The ManuFuture Road: Towards Competitive and Sustainable High-Adding-Value Manufacturing, Berlin, Springer.
- [5] Rother, M., Shook, J., 2003, Learning to See: Value-Stream Mapping to Create Value and Eliminate Muda, Lean Enterprise Inst., Version 1.3., Cambridge, Mass., Lean Enterprise Institute.
- [6] Kindler, E., 2004, On the Semantics of EPCs: A Framework for Resolving the Vicious Circle. In Business Process Management, pages 82–97.
- [7] Object Management Group, 2009, Unified Modeling Language (UML), Version 2.2.
- [8] Decker, G., Puhmann, F., 2007, Extending BPMN for Modeling Complex Choreographies. In: Proceedings of the 15th International Conference on Cooperative Information Systems (CoopIS), Springer.
- [9] Rodriguez, A., Fernandez-Medina, E., Piattini, M., 2007, A BPMN Extension for the Modeling of Security Requirements in Business Processes. In: IEICE Transactions on Information and Systems, 90(4), pp. 745-752.
- [10] Kalpakjian, S., Schmid, S., 2010, Manufacturing Engineering and Technology, Prentice Hall.
- [11] Pfadenhauer, K., Kittl, B., Dustdar, S., Levy, D., 2006, Shop Floor Information Management and SOA, Business Process Management Workshops, Lecture Notes in Computer Science, Volume 4103/2006, pp. 237-248.
- [12] Kanngießler, U., 2009, Can We Engineer Better Process Models?, In: Proceedings of International Conference on Engineering Design, pp. 527-538.
- [13] Scholz-Reiter, B., Böse, F., Teuke, M., Piotrowski, J., 2008, Integrated Planning and Control on RO-RO-Terminals, in: Proceedings of 7th International Workshop on Modeling & Applied Simulation, pp. 275-280.
- [14] Wohed, P., van der Aalst, W. M. P., Dumas, M., ter Hofstede, A.H.M., Russel, N., 2006, On the Suitability of BPMN for Business Process Modelling. In: 4th International Conference on Business Process Management, Austria.
- [15] Zur Muehlen, M., Recker, J., 2008, How much language is enough? Theoretical and Practical Use of the Business Process Modeling Notation, CAiSE '08 Proceedings of the 20th international conference on Advanced Information Systems Engineering.
- [16] Horváth, L., Rudas, I. J., 1998, Evaluation of Petri Net Process Model Representation as a Tool of Virtual Manufacturing, in: Proceedings of IEEE International Conference on Systems, Man, and Cybernetics, pp. 178-183.
- [17] Barber, K.D., Dewhurst, F.W., Burns, R.L.D.H., Rogers, J.B.B., 2003, Business-Process Modelling and Simulation for Manufacturing Management: A Practical Way Forward, Business Process Management Journal, Vol. 9 Iss: 4, pp.527 – 542.
- [18] Zor, S., Görlach, K., Leymann, F., 2010, Using BPMN for Modeling Manufacturing Processes. In: Proceedings of 43rd CIRP International Conference on Manufacturing Systems, pp. 515-522.
- [19] Kosanke, K., CIMOSA Association e.V., [http://www.cimosa.de/Standards/BPM\\_and\\_Standardisation.pdf](http://www.cimosa.de/Standards/BPM_and_Standardisation.pdf), last followed on February 15, 2011.
- [20] Hohpe, G., Woolf, B., 2008, Enterprise integration patterns: designing, building, and deploying messaging solutions, Addison-Wesley.
- [21] Schumm, D., Leymann, F., Streule, A., 2010, Process Viewing Patterns. In: Proceedings of the 14th International IEEE Enterprise Distributed Object Computing Conference (EDOC'10), pp. 89-98, IEEE Computer Society Press.
- [22] Schumm, D., Anstett, T., Leymann, F., Schleicher, D., 2010, Applicability of Process Viewing Patterns in Business Process Management. In: Proceedings of the International Workshop on Models and Model-driven Methods for Service Engineering (3M4SE), pp. 79-88, IEEE Computer Society Press.
- [23] Oryx Web page, <http://bpt.hpi.uni-potsdam.de/Oryx/>, last followed on February 15, 2011.